

# **Bell System (Telephones) Ltd.**

**bellagio**

**Digital**

**Video Door Entry System**

**Installation & Operation Manual**

**This manual applies to the following: -**

**BFD-DIG Digital Door controller – Version 2 Build 3 and up**

**BS Colour Videophone – Version 3 Build 4 and up**

**Tabellet Colour Apartment Station**

**XL5-BS Audio Phone**

**BSC4 Video Controller – Version 2 Build 7**

# BG bellagio Digital Video Entry System



BS videophone



Tabellet Apartment Station



XL5-BS audiophone



BS Deskphone



BSC4 controller



BFD-DIG controller



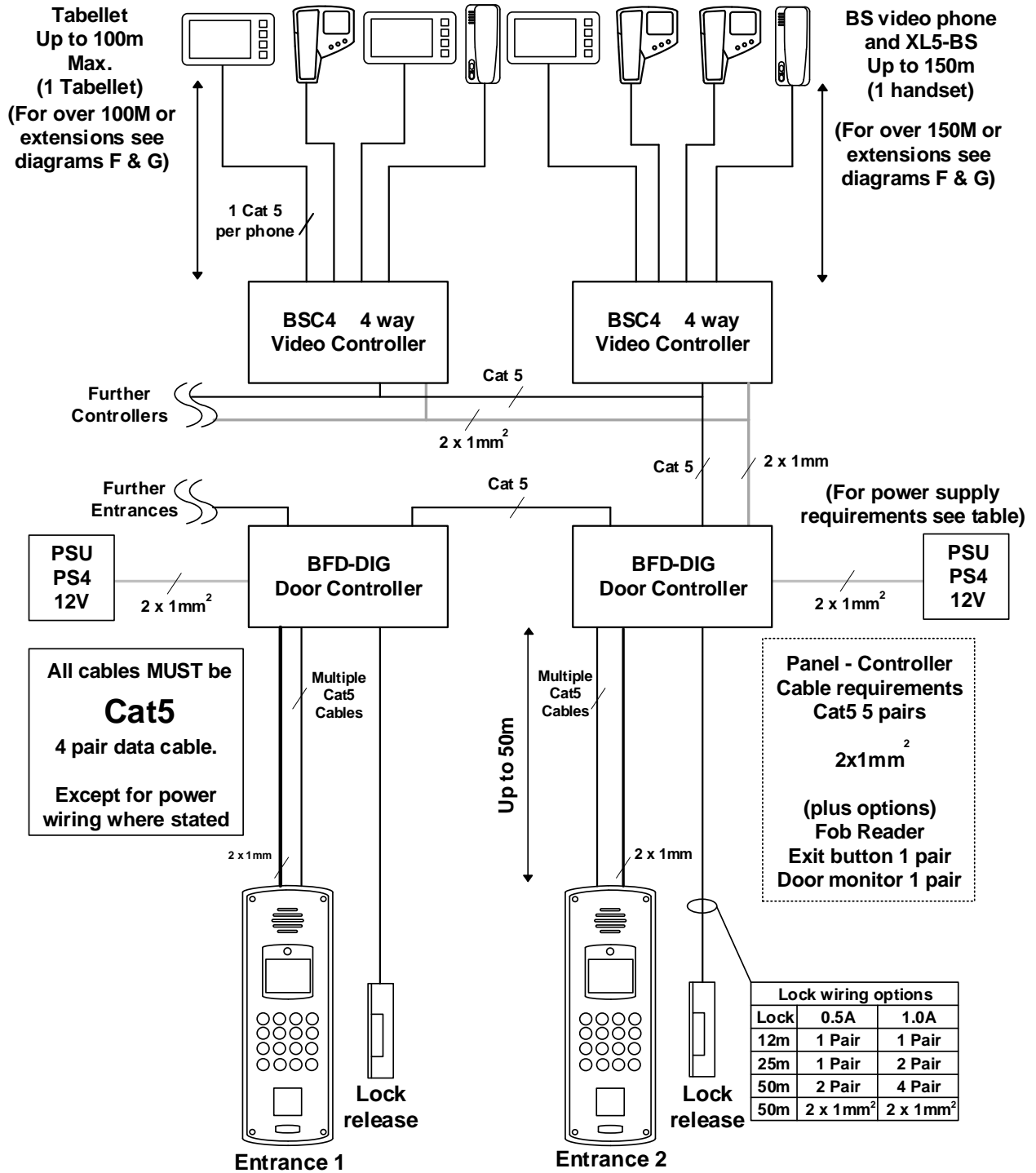
Bellagio Entrance Panel

## TABLE OF CONTENTS

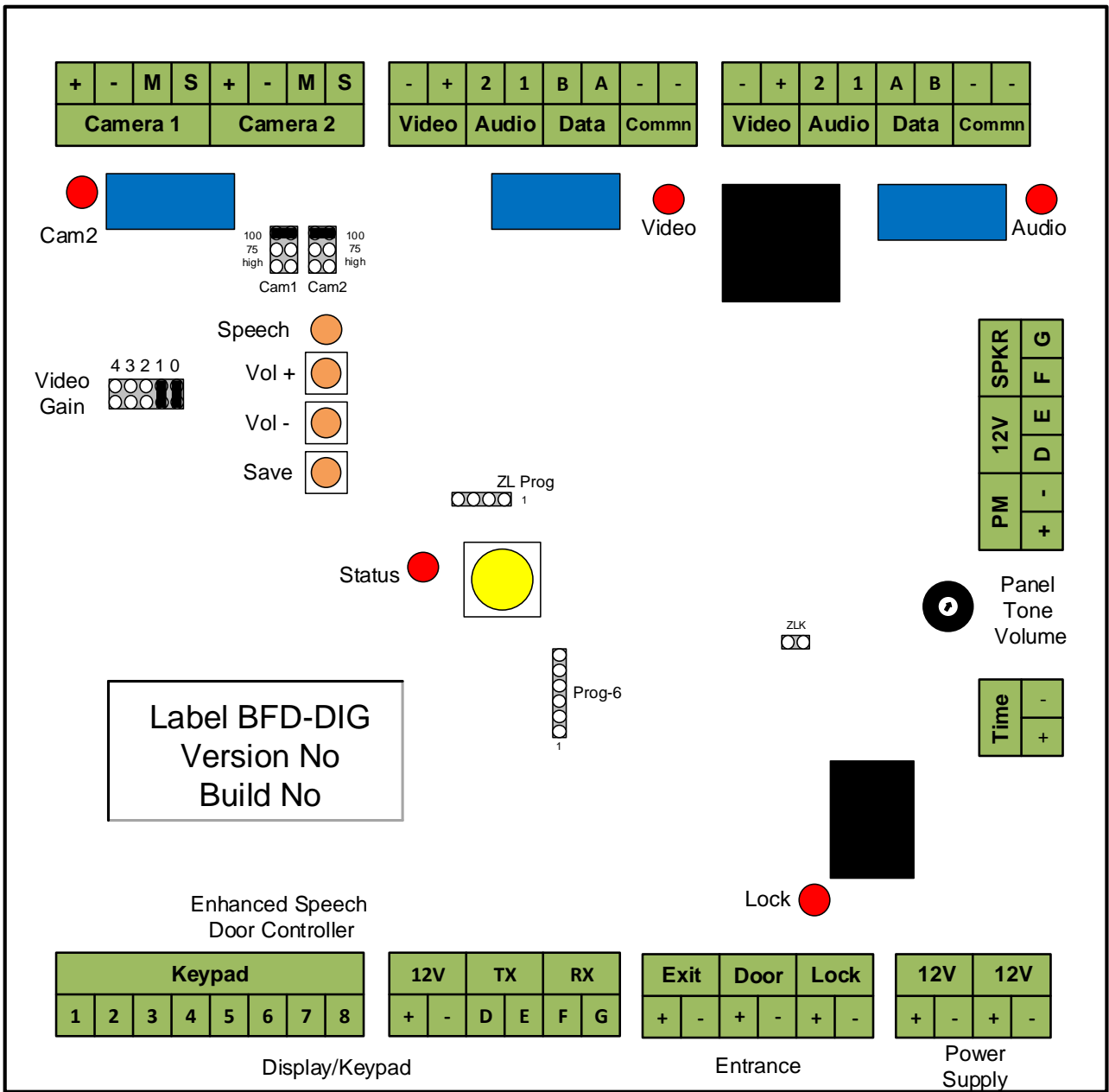
|  |           |
|--|-----------|
| <b>Diagram A – Basic System Wiring Overview</b> .....  | <b>5</b>  |
| <b>Diagram B – BFD-DIG PCB Detail</b> .....            | <b>6</b>  |
| <b>Diagram C – Basic System Wiring Detail</b> .....    | <b>7</b>  |
| <b>Diagram D – BSC4 PCB Detail</b> .....               | <b>8</b>  |
| <b>Diagram E – BSC4 Wiring Detail</b> .....            | <b>9</b>  |
| <b>Diagram F – Large system Overview</b> .....         | <b>10</b> |
| <b>Diagram G – Extension Videophone Wiring</b> .....   | <b>11</b> |
| <b>Diagram H – Videophone Local Power Wiring</b> ..... | <b>12</b> |
| <b>Power Supply Requirements</b> .....                 | <b>13</b> |
| <b>Cable Specification</b> .....                       | <b>14</b> |
| Cable Distances .....                                  | 15        |
| <b>Installation &amp; Commissioning</b> .....          | <b>16</b> |
| Checklist.....   | 16        |
| Wiring.....  | 16        |
| Tabellet .....   | 19        |
| <b>Commissioning</b> .....                             | <b>21</b> |
| BFD-DIG Door Controller Settings .....                 | 22        |
| BFD-DIG Door Controller Jumper Settings .....          | 26        |
| Door Speech Volume Adjustment .....                    | 27        |
| Bellagio Panel Option Settings.....                    | 28        |
| BSC4 Video Controller Settings .....                   | 29        |
| tabellet Apartment Station Switch Settings.....        | 31        |
| BS Videophone Switch Settings.....                     | 32        |
| <b>Troubleshooting</b> .....                           | <b>33</b> |
| Common Faults.....                                     | 33        |
| Quick Fault Reference .....                            | 33        |
| <b>Specifications</b> .....                            | <b>36</b> |
| <b>Safety Information and Declarations</b> .....       | <b>38</b> |

# BG bellagio Digital Video Entry System

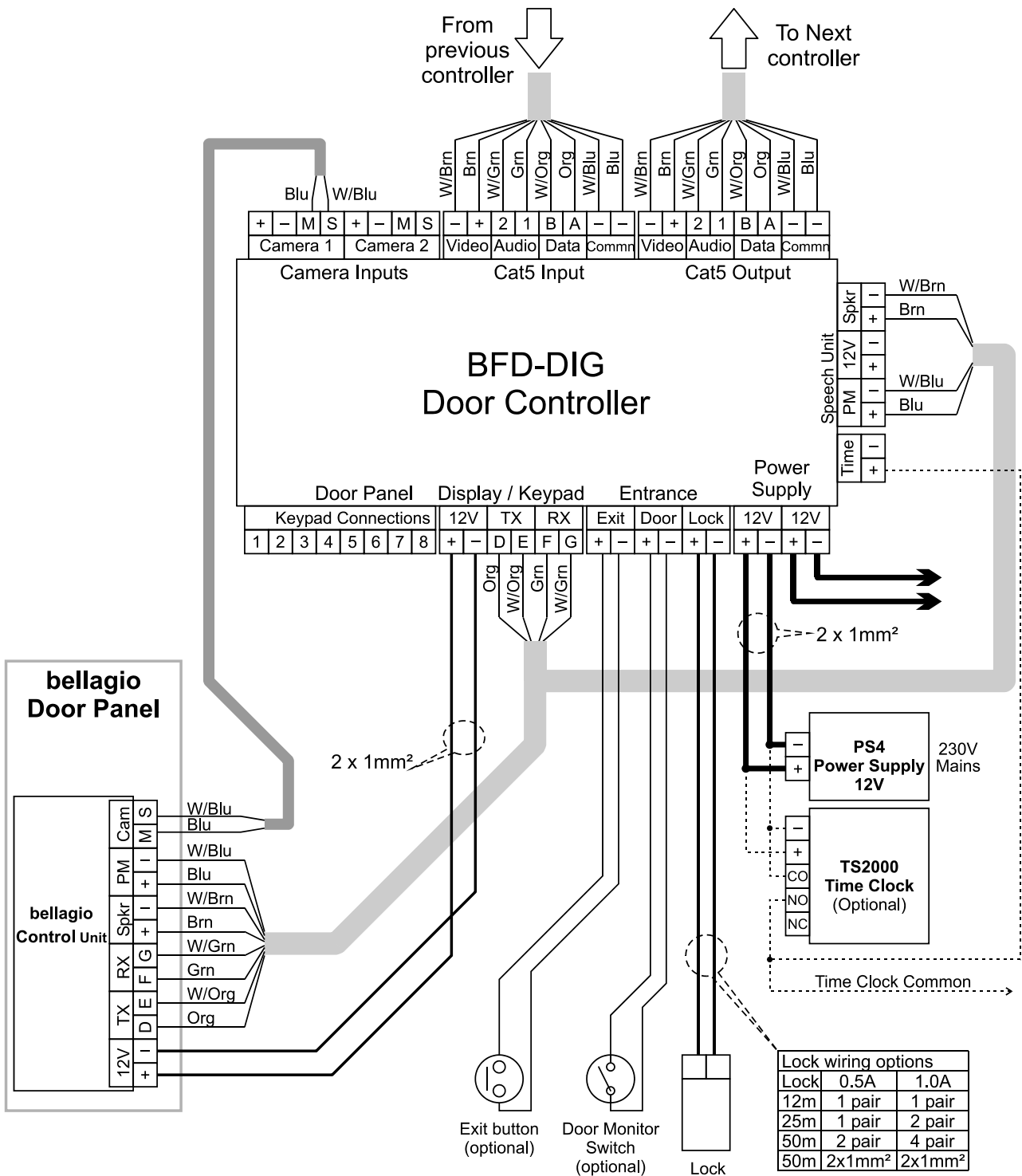
**Diagram A – Basic System Wiring Overview**



**Diagram B – BFD-DIG PCB Detail**



**Diagram C – Basic System Wiring Detail**



| Lock | 0.5A               | 1.0A               |
|------|--------------------|--------------------|
| 12m  | 1 pair             | 1 pair             |
| 25m  | 1 pair             | 2 pair             |
| 50m  | 2 pair             | 4 pair             |
| 50m  | 2x1mm <sup>2</sup> | 2x1mm <sup>2</sup> |

**All signal cable MUST be Cat5**  
**See "Cable Specification"**

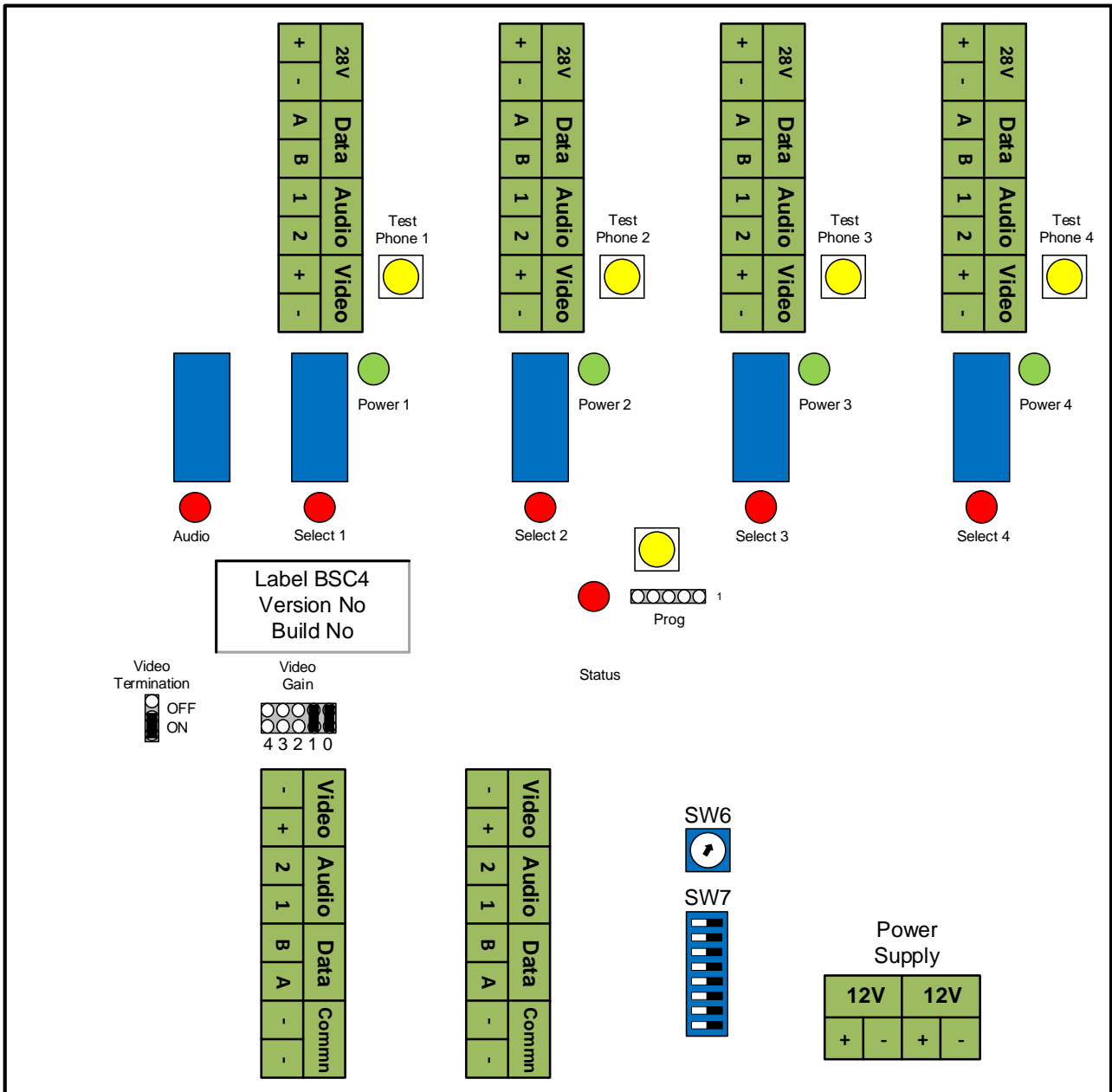
**Cat5 4 twisted pairs data cable.**

One pair in the Cat5 cable

A — B

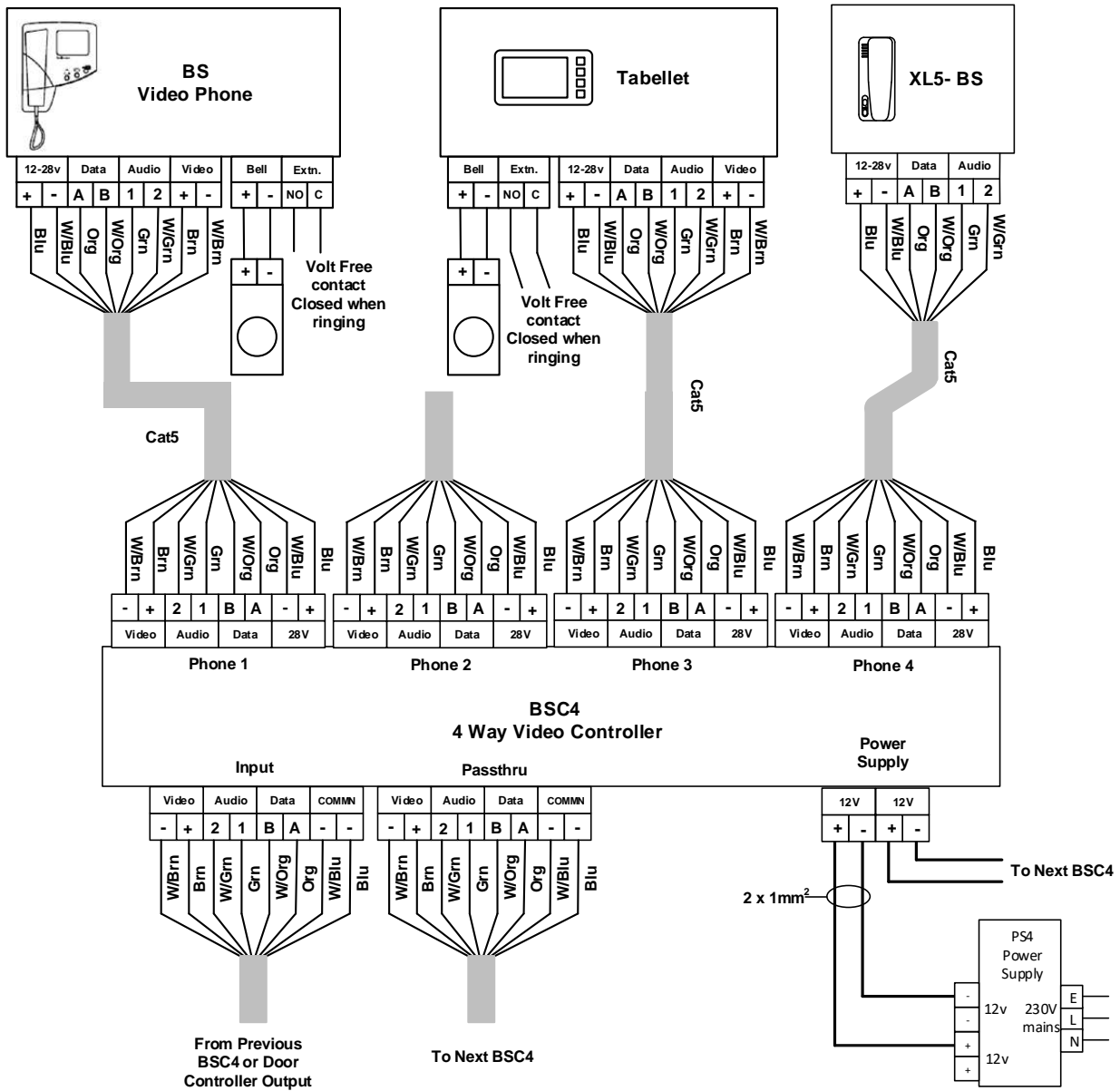
This symbol is used to indicate where a twisted pair connection must be used

Diagram D – BSC4 PCB Detail



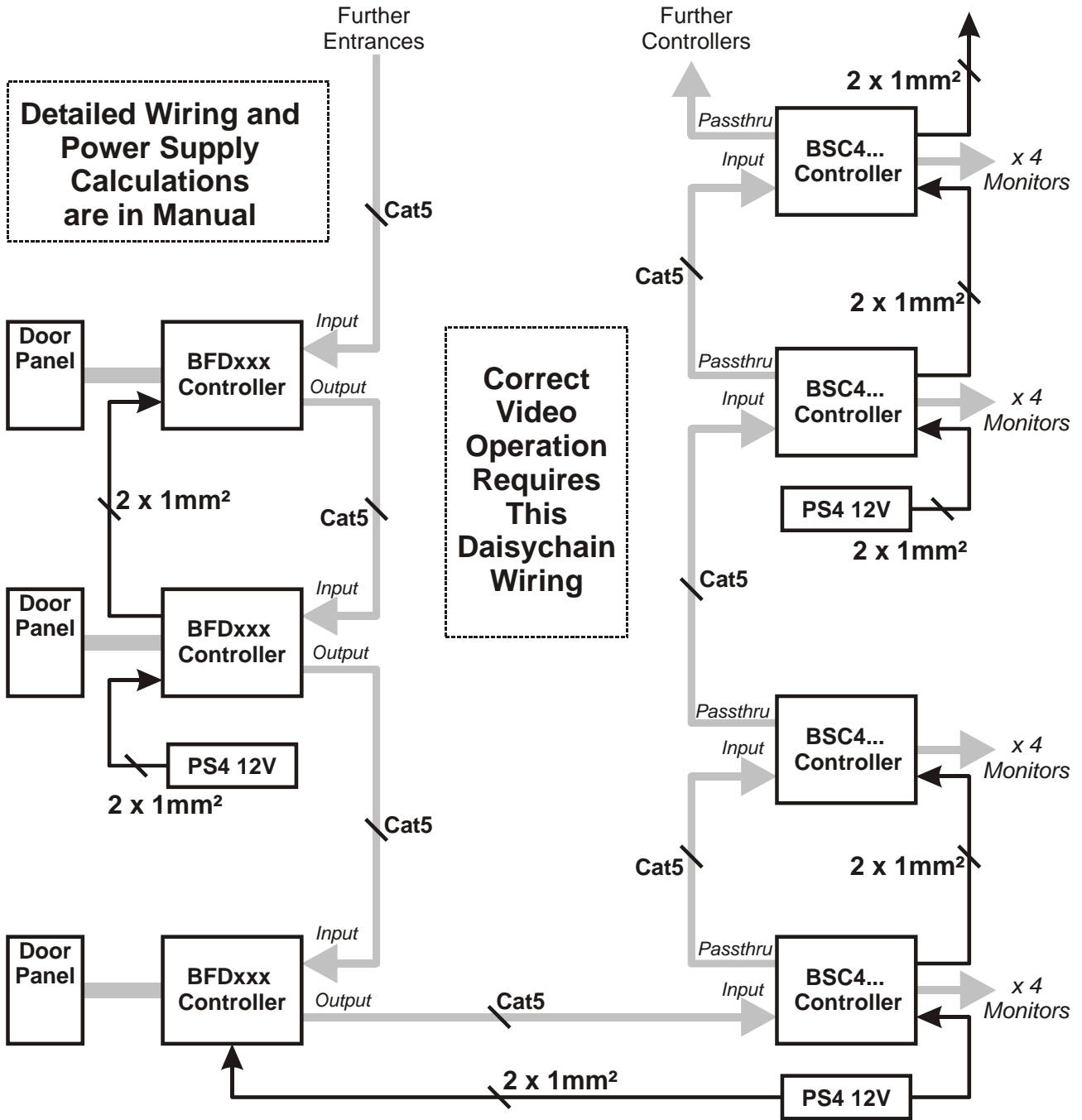


**Diagram E – BSC4 Wiring Detail**



## Diagram F – Large system Overview

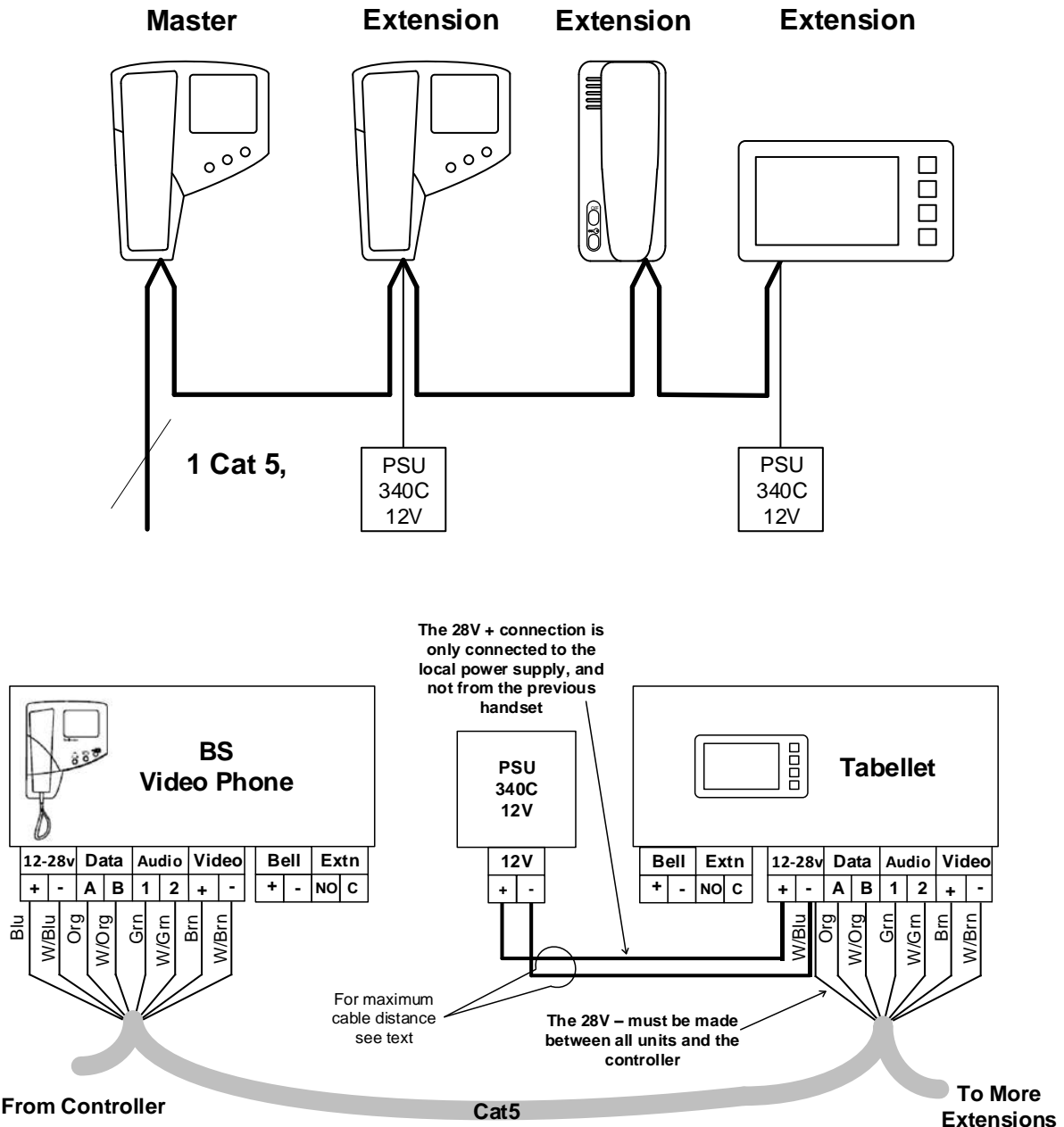
### Illustration of Power Supply Distribution





## Diagram H – Videophone Local Power Wiring

Where more than one extension video unit is required to provide "auto display" then additional power supplies will be required



### Note. For each cable run :-

- Only one unit must be Master (Recommend the first unit)
- Extension video units must be "daisy chain" wired to preserve video quality
- The last (or only) video unit on the cable requires the Video Terminator "ON" all other video units must have the Video Terminator "OFF"

## Power Supply Requirements

The system is powered by 12V power supplies only: -

Model PS4 12V, 4A.

Model 840 12V, 4A battery backup supply.

Model 340C 12V, 1.5A optional for extensions.

Note 1. The 28V referred to on the videophone, video controller and wiring diagrams is internally generated in the controller. DO NOT use any power supply other than 12V or damage may occur.

Note 2. The PS4 power supply has been specifically designed to operate with the high-surge requirements of the system. Bell System is unable to guarantee functionality or provide support for systems which use third party power supplies.

Exact power supply requirements depend upon many factors. The number of power supplies included within a standard 'kit' or quotation assumes that all controllers are installed in one location and that there are no extensions.

The following table gives examples of the minimum number of controllers and power supplies for a given number of entrance doors and flats.

| <b>System</b>   | <b>Control Equipment and Power Supplies</b>   |
|-----------------|---|
| 1 door 16 flats | 1 x BFD-DIG door controller for digital panel<br>4 x BSC4 video controller<br>2 x PS4 12V 4A power supply |
| 1 door 20 flats | 1 x BFD-DIG door controller for digital panel<br>5 x BSC4 video controller<br>2 x PS4 12V 4A power supply |
| 1 door 36 flats | 1 x BFD-DIG door controller for digital panel<br>9 x BSC4 video controller<br>3 x PS4 12V 4A power supply |
| 2 door 36 flats | 2 x BFD-DIG door controller for digital panel<br>9 x BSC4 video controller<br>4 x PS4 12V 4A power supply |

Distributed installations will typically require more power supplies. Also the use of other equipment such as coded access or proximity readers must be taken into account.

The following table is a guide to how much equipment a PS4 power supply can safely and reliably feed, please contact technical support for other variations.

## BG bellagio Digital Video Entry System

| Equipment 1 x PS4 can power  | Comments  |
|--|---|
| 4 x BSC4 video controllers with 1 videophone per output.                                       | 16 videophones directly powered. Extensions may be added if separately powered by 340C's.   |
| 2 x BSC4 video controllers with up to 4 videophones per output.                                | Extension phones must be set to ring only, use the above configuration to allow the extensions to have a picture while ringing.                             |
| 1 to 3 BSC4's with phones plus extensions  | 16 videophones directly powered   |
| 1 x BFD-DIG door controller and 2 x BSC4 video controllers with 1 videophone per output        | 8 videophones directly powered. Extensions may be added if separately powered by 340C's.  |
| 1 x BFD-DIG door controller and 1 x BSC4 video controllers with up to 4 videophones per output | Extension phones must be set to ring only, use the above configuration to allow the extensions to have a picture while ringing.                             |
| 2 x BFD* door controllers (any type) with up to 2 cameras and 1A fail safe locks.              | Both door controllers must be in the same location. No spare current available for other equipment unless both cameras or all the lock current is not used. |

### Cable Specification

All system wiring must be carried out using **Cat5** signal cable and where necessary 1mm<sup>2</sup> (or greater) power cable as tabulated below. Cat5 cable has a known performance for the transmission of video signals, whilst telephone or alarm cables are not suitable.

**Bell System will be unable to offer any warranty or support for systems installed using incorrect cables.**

#### Cat5 Cable Specification

Cat5 is our short reference for EIA standard UTP Category 5 Unshielded Twisted Pair data cable. This is a standard solid core twisted pair cable having 4 pairs (8-cores) and no shield. The cores are in pairs where Blue and 'Blue with a White stripe' are twisted together as the first pair. The other three pairs are similar with main colours Orange, Green and Brown.

- Also available and acceptable are:
  - UTP Category 5e (Cat5e)
  - UTP Category 6 (CAT6)
  - UTP Category 6e (CAT6e)

The exact cable can be chosen from the above on cost and availability grounds.

- STP (Shielded Twisted Pair) cables are **not** recommended.
- UTP "patch cables" are **not** recommended.

NOTE: Cat5 cable is easily identifiable as the specification is printed on the sheath

## Cable Distances

| Video Controller to Videophone                                     |               |                                  |   |
|--|---------------|----------------------------------|---|
| System   | Distance      | Cable                            | Comments  |
| Single videophone per output or first videophone                   | < 150m        | 1 x Cat5                         | Tabellet = <100m  |
|  | < 300m        | 1 x Cat5<br>2 x 1mm <sup>2</sup> |   |
| Single videophone + 3 extensions on each output, all cable powered | < 50m         | 1 x Cat5                         | Only Master videophone has 'Auto display'; extensions are daisy-chained       |
|  | < 200m        | 1 x Cat5<br>2 x 1mm <sup>2</sup> |   |
| Single videophone per output with separately powered extensions    | < 150m        | 1 x Cat5                         | 150m maximum to the cable powered videophone; daisy-chain up to 300m total.   |
|  | < 300m        | 1 x Cat5<br>2 x 1mm <sup>2</sup> |   |
| All videophones locally powered with a 340C power supply           | < 300m        | 1 x Cat5                         | Locally powered videophones have 'Auto display'; extensions are daisy-chained |
|  | <25m to 340C  | 1 x pair of Cat5                 |   |
|  | <100m to 340C | 2 x 1mm <sup>2</sup>             |   |

| Door Controller to Video Controller(s) |          |  |
|--|----------|--|
| Distance                               | Cable    | Comments   |
| <200m                                  | 1 x Cat5 | N.B. maximum total length from any camera to any videophone must be less than 300m |

| Entrance to BFD-DIG Door Controller |          |  |                         |
|-------------------------------------|----------|--|-------------------------|
| Connection                          | Distance | Cable                                      | Comments                |
| Entrance Panel                      | <50m     | 5 x pair of Cat5<br>+ 2 x 1mm <sup>2</sup> | See page 7 for details. |
| Lock Release up to 1A               | <10m     | 1 x pair of Cat5                           |                         |
|                                     | <50m     | 2 x 1mm <sup>2</sup>                       |                         |
| Option: Exit button                 | <50m     | 1 x pair of Cat5                           |                         |
| Option: Door Monitor Switch         | <50m     | 1 x pair of Cat5                           |                         |
| Option: Second Camera               | <50m     | 2 x pair of Cat5                           |                         |

| Power Supply to Controller               |          |                        |                                 |
|--|----------|------------------------|---------------------------------|
| System                                   | Distance | Cable                  | Comments                        |
| All Systems, each PS4 to BFD-DIG or BSC4 | <3m      | 2 x 1mm <sup>2</sup>   | Total length of any daisy chain |
|  | <5m      | 2 x 1.5mm <sup>2</sup> |                                 |

NB. A Cat5 cable has 4-pairs (8 cores)

For larger cable distances please contact manufacturer.

## Installation & Commissioning

### Checklist

The following checklist is a summary of what is required. Refer to the relevant pages for further details.

- Review the section headed 'Safety Information' on page 38.
- Ensure that 'Power Supply Requirements' on page 13 have been understood.
- Confirm that Cat5 cable has been specified.
- Install the system according to instructions in this section.
- Check/set the door controller settings.
- Check/set the video controller jumper and switch settings.
- Check/set each videophone dip-switch settings.

### Wiring

Refer to the diagrams from page 5 onwards as appropriate for the equipment you have.

All wiring is carried out using a mixture of Cat5 for the signal wiring and 1mm<sup>2</sup> (or greater) cores for the power wiring; refer to Page 14 for further details. It is strongly recommended that a consistent colour code be used throughout such as that indicated on the connection diagram. Certain signals must be interconnected using a twisted pair from the Cat5 cable. These are clearly marked on the connection diagram and should be strictly observed.

### Door Controller

The door controller and power supply should be wall-mounted in a convenient cupboard or other protected environment with available mains power. Cable length to the entrance should be less than 50m. The door controller for the second and subsequent entrances may be situated in the same location, or to meet the 50m requirement may be situated in another location. Power supplies may be shared between door controllers placed in the same location, but controllers in separate locations must be separately powered.

### Video Controller

The video controller(s) and power supply(ies) should be wall-mounted in a convenient cupboard or other protected environment with available mains power. Cable length to the videophone should be less than 150m, see 'Cable Distances' page 15. In many cases the video controllers will be in the same location as the door controller(s), but they may be distributed as required to reduce wiring distances. When placed in different locations, each location must have its own local power supplies.

### Gate Controller

The gate switch controller BSSW is wired between the block door controllers and the video controllers, so would normally be wall mounted next to a door controller.

For further details see the "Bellissimo and Bellcall Manual Gate and Block (PD-120)".



## **Electric Door Release**

Both fail-secure and fail-safe lock releases (including magnetic locks) use the same terminals. To set the lock type, refer to the 'Door Controller Settings'. When installing lock releases please allow a little movement on the door, as operation will be impaired if fitted too tight.

NB. Magnetic locks (maglocks) must be fitted with a suppressor at the lock terminals. Some manufacturers fit an acceptable internal suppressor.

## **Fail Safe Exit: Notes**

Fail safe exits require an exit button and this should be normally open so that the controller can be used to give a timed exit. If the exit button has both normally open and normally closed contacts, then the normally closed contact can be wired in series with the release or maglock along with the break glass in case of equipment failure.

A not uncommon problem with maglocks, because they cannot be mechanically overridden, is being locked out of the building due to lost codes, fobs or equipment failure. So consider an alternate building entrance, or an externally accessible secure keyswitch, or a reliable method of disabling the system during overnight secure lockup.

## **Fail Secure Exit: Notes**

Commonly fail secure exit doors incorporate a thumb-turn, door handle or mini push bar rather than use of an exit button. Fire officers usually require a minimum of door handle or push bar to open a door on a fire exit route – not a thumb-turn.

Most fail secure locks are not continuously rated and if an electrical hold open system is used for say busy times, then a continuously rated release must be used.

Powered bolt, shoot-bolt or other more secure door locking systems may require the use of separate power supplies or a suppressor to be fitted. Shoot-bolt systems for instance tend to require at least 1.5A peak current and this will require the use of an isolation relay and a separate power supply for the lock.

## **Exit Button and Emergency release**

An input is provided for an exit button, with normally open contacts, which can be installed on the inside of the door and allow residents to exit freely. Momentary operation of this button will operate the lock release for the programmed lock time. Emergency door release or other override device should cut the power to a Fail-Safe lock. Note: The installer should not rely on an electric operation to release the lock in the event of an emergency, as malfunction of the control equipment may prevent the safe exit from the building.

## **Door Open Switch**

The door open switch is used to provide an indication at the videophone that the door has been left open. This switch can have closed contacts when the door is closed or open contacts when the door is closed, the choice being made in Panel Programming. The default of 'contacts open when door closed' must be selected when this feature is not required.

## **Time Clock Sharing**

In a large system a single time clock can be shared between distributed equipment areas by borrowing one of the 'comm -' wires in the interconnecting Cat5 to use as the shared "Time clock common". This is detailed in a supplement, see Other Diagrams.

# BG bellagio Digital Video Entry System

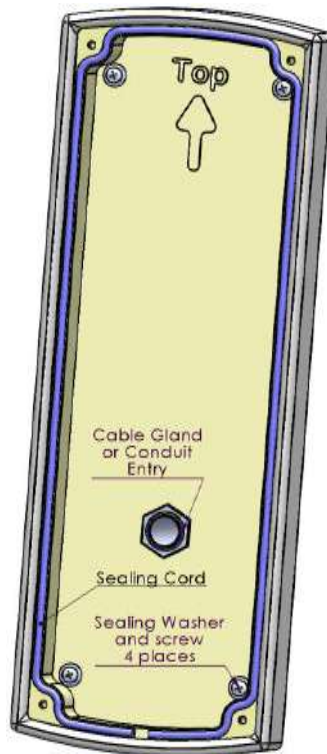
## Entrance Panel

The panel should be mounted at an optimum height of 1600mm, measured between the ground and the centre of the camera window. However, building regulations may require that the panel is mounted with the top row of buttons at 1200mm above ground.

On construction sites the panel and surround must be protected from corrosive substances such as 'brick acid'. The panel should be cleaned only with a damp cloth containing dilute detergent.



Bellagio with Fob



Installing the Back Box



Close up of Washers

The Bellagio panel is constructed to be water tolerant and it is important to install the panel carefully to avoid compromising the seals.

Neoprene backed washers are provided to seal the main mounting holes. A 20mm conduit entry allows the back-box to be sealed from water ingress at the cable entry by use of either a conduit seal or a cable gland – see diagrams below.

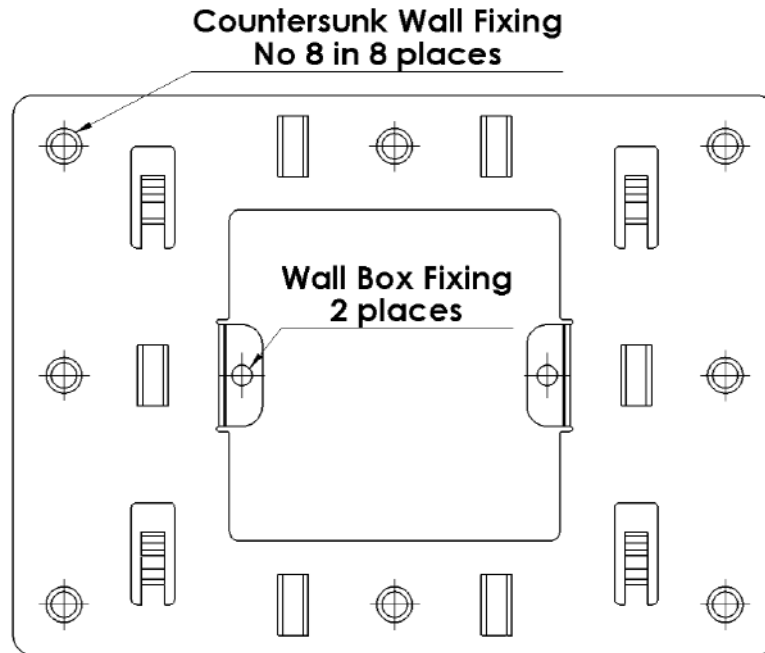
Sealing cord is pressed into a channel to provide the panel seal. Take care not to damage or remove this cord.

Careful consideration should be given to the location of the entrance panel to ensure the best possible lighting conditions for the camera. In general strong back lighting of the subject (by the sun and sky) should be avoided, as the contrast between foreground and background may be too great for the camera. The field of view should contain as little of the sky as possible, particularly if south facing. If a backlit situation is unavoidable, additional lighting may be necessary to illuminate the caller and avoid a dark outline image (silhouette). A light coloured or reflective surface around the panel will redirect backlight to illuminate the caller.

## Tabellet

The tabellet is designed to be surface mounted onto a plaster or plasterboard wall using the supplied steel bracket. The optimum screen height is 1.6m however DDA considerations may reduce this height to 1.4m.

### Instructions:



**Warning.** The heads of the countersunk screws must protrude less than 1mm or there will be difficulty attaching the apartment station to the plate.

- 1) Using the bracket as a template, cut a square hole into the plasterboard ensuring that the terminal block and other components on the back of the tabellet will clear.
- 2) A back-box is not required, however a standard flush-mounted single gang back-box can be fitted if desired. The back box does not have to be secured to the bracket but if this is desired, it is recommended that the bracket and back box be bolted together first and then fitted to the wall as a single item.
- 3) Fix the bracket to the plasterboard using up to 8-off No8 (4mm) screws and suitable plasterboard plugs. Ensure that the bracket is absolutely level when fitted.
- 4) Fit the tabellet unit by aligning it onto the 4 hooks of the wall bracket, and then pushing gently towards the wall and sliding the tabellet down until it “clicks” into place.
- 5) The tabellet can be removed from the wall mounting box by pushing upwards until it slides off the bracket. When up far enough it will come forward and the wiring can be accessed.

## Doorbell

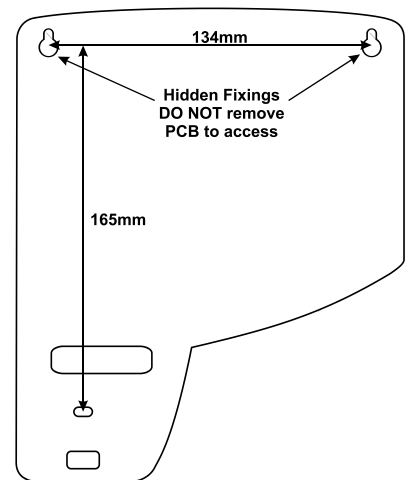
The tabellet has a doorbell function which typically would be operated by a local, non-illuminated door push having a normally open contact.

## BS Videophone

The videophone is designed to be wall mounted onto plasterboard or other masonry at an optimum height of 1.6m. It should be fixed with three No 8 pan head screws (not supplied). Use the dimensions shown on the adjacent diagram. If the cable is to be fed from the wall cavity then make a hole for this at the same time, the surface cable exit is to the left of the cut-out. The top two screws are hidden fixings, so screw in but do not fully tighten. Test hang the videophone and adjust the screws as required.

Now remove the top cover of the videophone, which is secured by a clip at the bottom. Hang the videophone on the two screws already fitted allowing the cable (if present) to feed through and the third screw to be inserted at the bottom. Tighten the third screw.

If the silicone rubber buttons fall out, clip them back into the PCB. Before replacing the Front Cover remove the protective film from the display lens and also check that the Dip Switch settings are correct or change as necessary (see Page 32).

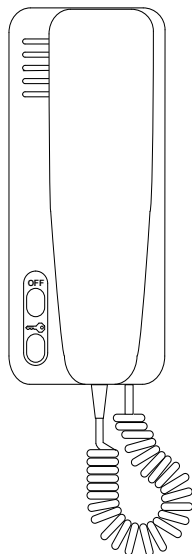


## Separately Powered Videophones

The limitation of up to 4 videophones ringing but only one displaying, as indicated in the power supply and cable distance tables on page 15, can be overcome by the use of supplementary power from a 340C.

## XL5-BS Phone

The XL5-BS audio phone can be used as a lower cost alternative to an extension videophone. It is styled like the bellissimo videophone. The phone is manufactured in white and grey high-impact ABS plastic that imparts high durability and compliments most wall furnishings. It incorporates both **mute** and **lock** illuminated buttons and it has an Electronic Ringing Tone with rotary preset volume.



## Commissioning

The major components of the bellagio Digital system are fitted with high quality pluggable screw terminal blocks. This enables all the connections to the system to be fully completed, whilst easily isolating individual pieces of equipment during testing and commissioning.

When powering up for the first time, it is highly recommended that only the most basic system be connected. i.e. 1 videophone, 1 door controller and panel, and 1 video controller; the remaining equipment can be isolated by unplugging terminal blocks.

NB: Ensure the 1 door and video controller remain interconnected and that the 'end of line' controller is terminated temporarily using the jumpers (see page 29).

Proceed to test the system by calling the videophone from the door panel in the usual way. Any problems can be resolved by rechecking wiring and connections, assisted by the various suggestions and tests in the section "Troubleshooting". Once the basic system is fully functioning, continue to reconnect and test the remaining equipment item by item until completed.

## BFD-DIG Door Controller Settings

The BFD-DIG is programmed from the panel for all settings.

### Security

It is strongly recommended that the Panel Security Code be changed from its factory setting to prevent unauthorised access. Record the new number carefully as it cannot be easily changed if lost. It is also recommended that the Phone Programming Code, Coded Access Code and Trades Access Code are all changed from default even if not used.

To access panel programming without the code requires physical access to the controller PCB, borrow a jumper from say video gain (remember the setting) and place it on the 6 pin programming header between pins 5 & 6. Now pressing the test button will enter panel programming for 30S when the panel security code can be read or set. When the programming is finished replace the jumper back to its original location.

### Panel Programming

- First type the Panel Security Code (initially [3434]) followed by the **bell** button.
- The display will show the first programmable parameter and the current value.





Numeric Entry



bell Button Toggles Value

- Press the **key** button to step down through the programmable parameters.
- Press the **reception** button to step up through the programmable parameters.
- N.B. The display may take up to 2 Seconds to refresh.
- The list rolls over bottom to top and vice versa.
- To change a numeric parameter simply type a new 1-4 digit value and then press **bell**.
- To change other values simply press **bell** to choose the next value.
- To exit Panel Program Mode press **cancel**.
- If no button is pressed for 30 seconds then programming mode will auto-cancel.

**Summary**

| Parameter Name | Default | Access  | Description                                       |
|----------------|---------|---|---|
| Access Code    | 1234    | ↑↑  | Coded access code – must be 4 digits              |
| Trades Code    | 6789    |   | Trade access code – must be 4 digits              |
| Lock Time      | 3       |   | Lock Time: 1-99 seconds                           |
| Lock Type      | Secure  |  | Lock Type: Secure (fail secure), Safe (fail safe) |
| Camera 2       | No      |   | Camera 2: No (absent), Yes (present)              |
| Trade Function | 5       |   | Trade Function: 0-9 – see table                   |
| Door Mon Pol   | Cwo     |   | Door Monitor Polarity: Cwo, Owo                   |
| Reception No   | 9898    |   | Reception / Porter phone number                   |
| Security Code  | 3434    |  | Panel security code                               |
| Phone Code     | 1212    |   | Phone programming security code                   |
| Ring Time      | 15      |   | Ring Time – see table                             |
| Talk Time      | 15      |   | Talk Time – see table                             |
| Tone Mode      | Both    |   | Ring and Lock Buzz-Tone enable, 4 settings        |
| Cancel         | Yes     | ↓↓  | Allow <b>Cancel</b> button to terminate Call      |
| BellCall       | No      |   | Bellcall BCP1 compatibility mode                  |
| 12A to 13      | No      |   | Allows user entry of 12A to call BSC4 output 13   |
| Reception      | Yes     |   | Enables Reception function button                 |

**ACCESS CODE – Primary Access Code**

Main code to open the door. Applies whenever the display indicates “Enter Code”. The Trades Function needs to be set to ‘Code’ or ‘Trade’ as per the table below.

The code must be 4 digits and no letters, leading 0 is OK (e.g. [0246]).

**TRADES CODE – Secondary Access Code or Tradesmen’s Code**

Secondary ‘tradesmen’s’ code to open the door. Valid only when the display indicates “Enter Code” and the time clock selects the Trade option as per the table below.

The code must be 4 digits and no letters, leading 0 is OK (e.g. [0137]).

**LOCK TIME – Lock Release Operating Time**

Door unlocked duration. Range 1 to 99 seconds. Only the last 2 displayed digits are used. A value of 0 will default to 1 second and a value containing alpha characters will default to 3 seconds.

**LOCK TYPE – Lock Type**

[Secure] = Fail secure lock: – Requires alternate mechanical means, key or thumb-turn to open on power failure.

[Safe] = Fail safe lock: – Lock opens on power failure.

**CAMERA 2 – Second Camera Present?**

[No] = Only 1 camera,

[Yes] = Second camera present.

# BG bellagio Digital Video Entry System

## TRADE FUNCTION – Door Button Trades Mode

Choose the Mode value 0-9

| Setting        | [0]  | [1]  | [2]  | [3]   | [4]   | [5]         | [6]  | [7]   | [8]   | [9]  |
|----------------|------|------|------|-------|-------|-------------|------|-------|-------|------|
| Time Clock Off | None | None | None | None  | Code  | <b>Code</b> | Code | Trade | Trade | Door |
| Time Clock On  | None | Door | Code | Trade | Trade | <b>Door</b> | Code | Trade | Door  | Door |

'None' = No function; pressing the **door** button is ignored.

'Door' = Pressing the **door** button opens the door.

'Code' = Pressing the **door** button prompts for the Access Code to open the door.

'Trade' = Pressing the **door** button prompts for either the Access Code or Trades Code to open the door.

## DOOR MON POL – Door Status Switch

[Owc] = Contacts open when door is closed: – The default allows for no switch fitted.

[Cwc] = Contacts closed when door is closed: – Standard normally closed switch.

## RECPTION No – Reception Phone Address

The **reception** button is used to call a reception desk or similar. The number is that of the called phone. The default is [9898] which is unlikely to be used by a flat.

## SECURITY CODE – Panel Security Key

The security key is required to gain access to panel programming.

The code is entered then pressing the **bell** button, the default is [3434] and it is recommended that this be changed for security.

This code can contain letters and numbers for added security.

## PHONE CODE – Phone Programming Security Key

The phone programming security key is required to gain access to flat number programming of telephones. The default is [1212] and it is recommended that this be changed for security.

This code can contain letters and numbers for added security.

This function is for when the BFD-DIG is used in systems where BSC4 programming cannot cope with the required complexity.



# BG bellagio Digital Video Entry System

## RING TIME – Ringing Time/Call Time and Ring Effect

Enter from 0 to 15 as per the table

| Setting   | Ring Time   | Ring Cadence or Sound Effect            |
|-----------|-------------|---|
| 0         | 5s          | 1 in 3 – 1 ring every 3 seconds         |
| 1         | 8s          | 1 in 3 – 1 ring every 3 seconds         |
| 2         | 10s         | 1 in 3 – 1 ring every 3 seconds         |
| 3         | 15s         | 1 in 3 – 1 ring every 3 seconds         |
| 4         | 20s         | 1 in 3 – 1 ring every 3 seconds         |
| 5         | 30s         | 1 in 3 – 1 ring every 3 seconds         |
| 6         | 40s         | 1 in 3 – 1 ring every 3 seconds         |
| 7         | 45s         | 1 in 3 – 1 ring every 3 seconds         |
| 8         | 50s         | 1 in 3 – 1 ring every 3 seconds         |
| 9         | 60s         | 1 in 3 – 1 ring every 3 seconds         |
| 10        | 30s         | 1 in 3 (Reserved For future use)        |
| 11        | 30s         | 1 in 3 (Reserved For future use)        |
| 12        | 30s         | 2 in 15 – 2 rings, 15S silence, repeat  |
| 13        | 30s         | 1 in 15 – 1 ring, 15S silence, repeat   |
| 14        | 30s         | 1 in 5 – 1 ring every 5 seconds         |
| <b>15</b> | <b>30s*</b> | <b>1 in 3* – 1 ring every 3 seconds</b> |

\* Default setting

## TALK TIME – Talking Time/Videophone Active

Enter from 0 to 15 as per the table

| Setting | Talk Time | Setting | Talk Time | Setting | Talk Time | Setting   | Talk Time   |
|---------|-----------|---------|-----------|---------|-----------|-----------|-------------|
| 0       | 15s       | 4       | 60s       | 8       | 150s      | 12        | 60s         |
| 1       | 20s       | 5       | 75s       | 9       | 180s      | 13        | 60s         |
| 2       | 30s       | 6       | 90s       | 10      | 60s       | 14        | 60s         |
| 3       | 45s       | 7       | 120s      | 11      | 60s       | <b>15</b> | <b>60s*</b> |

\* Default setting

## tone mode – Re-assurance Tone

To conform to DDA requirements the controller can provide a re-assurance tone at the door when an videophone is being called and also when the door lock has been operated.

The volume is adjustable from 0 using the volume control on the BFD-DIG controller PCB (see the diagram on page 6). In addition there is a choice of which tone is sounded.

Four settings are available: –

[Both] = Ringing and lock tones.

[Call] = Ringing tone only.

[Lock] = Lock tone only.

[None] = No tones.

## BG bellagio Digital Video Entry System

### **CANCEL – Cancel Key Compatibility**

For use with a new controller in older systems with any BSC4 video Controller below Build 4, or BS801 audio phone below Build 6, or BC801 or BC801P audio phones below Build 6. These older systems are not capable of cancelling a call and the phones will continue to ring even though the door controller has closed down.

If this situation applies then ensure “Cancel” is set to [No] otherwise the default is [Yes].

### **BELLCALL – Bellcall Compatibility Mode**

For use in mixed systems with a BCP1 panel revision V2.0 upwards. Switching compatibility mode to [Yes] changes the number format for addressing a phone and removes the 3 Second overhang of speech when operating the lock from a phone.

BS801 audio phones from Build 6, or BC801 or BC801P audio phones from Build 6, and all BSA phones already have number format transparency built in and do not need this switch.

Default is [No], set to [Yes] only when in a mixed BCP1 with older phones.

Must be set to [No] when addressing any apartment station or videophone.

### **12A TO 13 – Flat 13 Numbered as 12A**

For use when flat numbering is ... 11, 12, 12A, 14, 15 ... When set to [Yes] entering “12A *bell*” will actually send “13” so that the BSC4’s can be set to respond to ... 11, 12, 13, 14, 15 ...

### **RECEPTION – Is Reception Button Allowed**

This is used in conjunction with the Bellagio Panel Dip Switch setting to enable the display of the reception function.

## **BFD-DIG Door Controller Jumper Settings**

See the diagram on page 6

### **Camera Terminator**

There is a separate jumper for both video Camera inputs. This has three settings, 75R for terminating coaxial cable, 100R for terminating twisted pair Cat5 cable and None for use when passing the cable on to another device or controller.

### **Video Gain Control**

The ‘Video Gain’ jumper on door controllers should always be set to ‘0’ unless directed by ‘Bell System Technical Support’. This jumper is only required on some systems with very long cable runs, camera to videophone well in excess of 150m. Inappropriate use of this jumper with short runs will cause picture problems.

## Door Speech Volume Adjustment

### Introduction

The speech level heard by a caller at the door is adjustable by use of three pushbuttons on the BFD-DIG door controller. This is useful if the door is on a noisy street, or alternatively in a quiet location. Speech gain in the other direction is fixed.

### Method

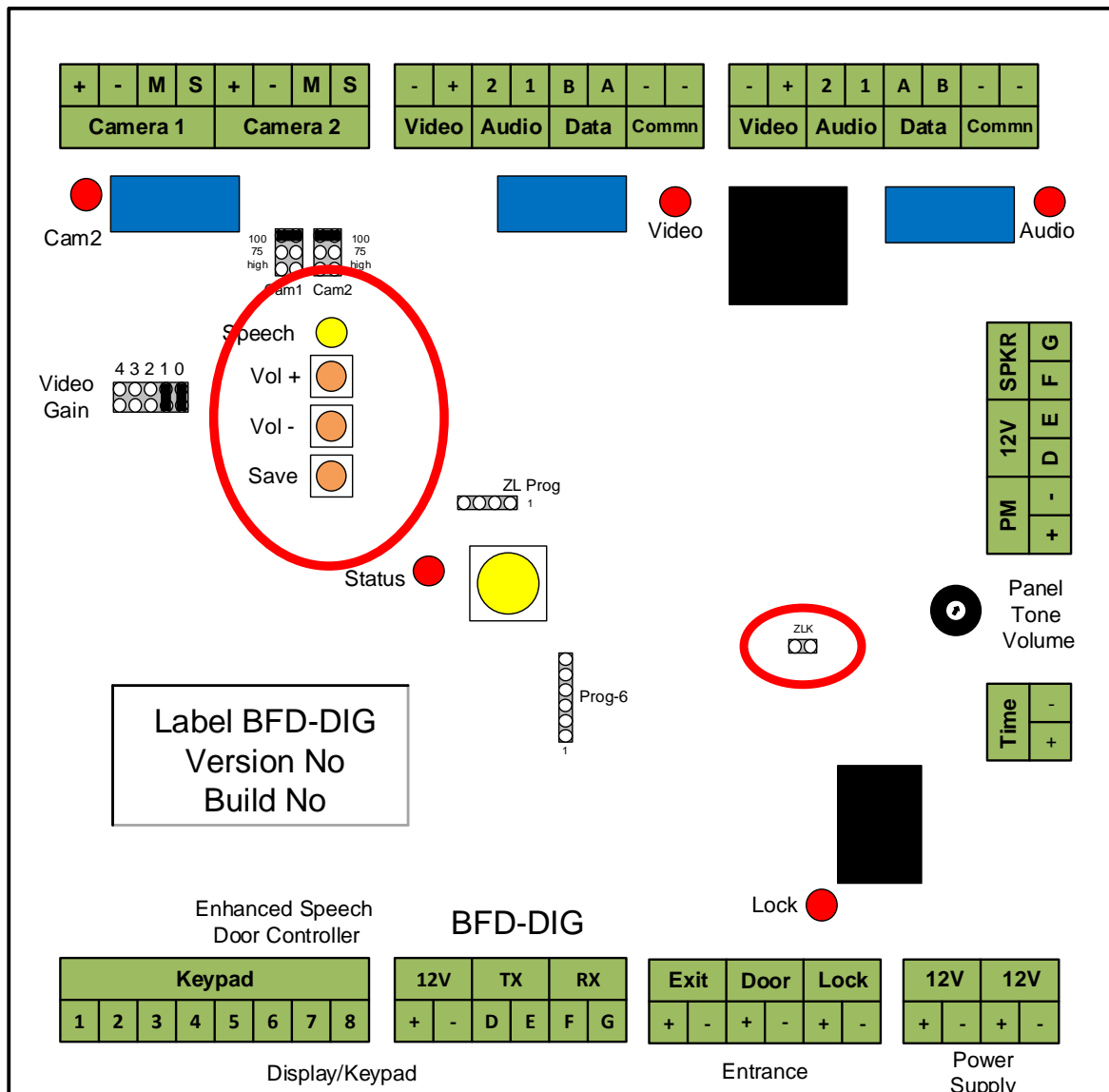
To perform volume adjustment, first borrow the jumper from Prog-6 and place it on the two pin header ZLK. The Yellow Speech LED should light.

**WARNING.** A power fail during a Save may require the unit to be returned to Bell System for reprogramming. Do not perform volume adjustment without the jumper in place.

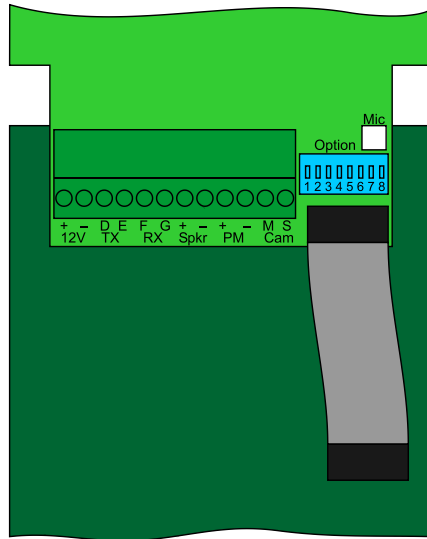
8 presses of Vol+ doubles the volume level and 8 presses of Vol- halves it. Pressing Save stores the new value. Increasing the volume too far will make speech less stable and there will be a tendency for feedback – intermittent screeching and howling. If this happens press Vol- four times and Save and test again.

The new level is tested by ringing one or more videophones and talking to them.

Finally return the jumper to its original location on Prog-6.



## Bellagio Panel Option Settings

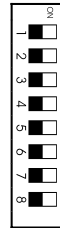


### Panel Options Switch

The panel options switch is used to set custom options for the panel display. The Switch settings are in the table, however some settings may need to be made in conjunction with the Door Controller Settings. E.G. Reception Shown.

| Bit | Function  | Bit Off (Default)                | Bit On                        |
|-----|-----------|----------------------------------|-------------------------------|
| 1   | Spare     |                                  |                               |
| 2   | Spare     |                                  |                               |
| 3   | Spare     |                                  |                               |
| 4   | Spare     |                                  |                               |
| 5   | Spare     |                                  |                               |
| 6   | Spare     |                                  |                               |
| 7   | Concierge | Display shows Reception          | Display Shows Concierge       |
| 8   | Reception | Reception/Concierge Button Shown | Reception/Concierge Not Shown |

Switch



OFF ↔ ON

## BSC4 Video Controller Settings

### Jumper settings

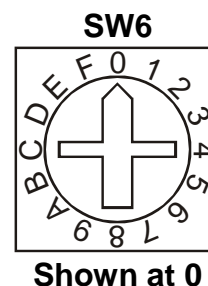
The “Video Gain” jumper on video controllers should always be set to “0” unless directed by Bell System Technical. This jumper is only required on some systems with very long camera to videophone cable runs well in excess of 150m. Inappropriate use of this jumper with short runs will cause picture problems.

The “Video Terminator” jumper must be set to OFF on all but the furthest Video Controller from the Door Controller(s), this one must be set to ON.

### Switch settings

SW6 is a rotary 16 position switch which sets the videophone addresses as per the following table. These numbers represent actual flat numbers for the digital controller; they also correspond to the inputs on the BFD8 or BFD72.

| SW6 Setting |         |         |         |         |
|-------------|---------|---------|---------|---------|
| Pos         | Phone 1 | Phone 2 | Phone 3 | Phone 4 |
| 0           | None    | None    | None    | None    |
| 1           | 1       | 2       | 3       | 4       |
| 2           | 5       | 6       | 7       | 8       |
| 3           | 9       | 10      | 11      | 12      |
| 4           | 13      | 14      | 15      | 16      |
| 5           | 17      | 18      | 19      | 20      |
| 6           | 21      | 22      | 23      | 24      |
| 7           | 25      | 26      | 27      | 28      |
| 8           | 29      | 30      | 31      | 32      |
| 9           | 33      | 34      | 35      | 36      |
| A           | 37      | 38      | 39      | 40      |
| B           | 41      | 42      | 43      | 44      |
| C           | 45      | 46      | 47      | 48      |
| D           | 49      | 50      | 51      | 52      |
| E           | 53      | 54      | 55      | 56      |
| F           | 57      | 58      | 59      | 60      |



#### ATTENTION

Each SW6 MUST be set correctly for the phones to ring.

This switch is shipped set to 0 to prevent multiple phones ringing on initial installation.

### Address Offset SW7

SW7 is an 8 bit switch that is used to increase the addressing range. For each bit that is switched ON add the corresponding value to the amount set by SW6. This allows flat addresses up to 3210 to be set (6410 or higher with the jumper below).

| Bit | Offset |
|-----|--------|
| 1   | +1     |
| 2   | +2     |
| 3   | +50    |
| 4   | +100   |
| 5   | +200   |
| 6   | +400   |
| 7   | +800   |
| 8   | +1600  |

Each bit on SW7 adds the corresponding amount to the address set by SW6. Do not set a total value above 9995

#### SW7



OFF ↔ ON

## **Odd/Even Addressing Jumper PROG pins 1-2**

This jumper alters the addressing of Phone outputs 2, 3 and 4 such that they all become either odd or even numbers. So if the address of output Phone 1 is 12 say the other outputs become 14, 16 and 18. If the address were 31 then the other outputs are 33, 35 and 37.

The use of this jumper precludes the use of extended addressing by PROG pins 2-3, if both are required contact Bell System Technical. The jumper is stored on pins 4-5.

## **Extended Addressing Jumper PROG pins 2-3**

This jumper adds +3200 to the Phone 1 address set using SW6 and SW7. Phone addresses up to 6410 (Phone 1 output) can be set. Custom versions will show the custom offset on the build label.

The use of this jumper precludes the use of Odd/Even addressing by PROG pins 1-2, if both are required contact Bell System Technical. The jumper is stored on pins 4-5.

## **Custom Alternate Addressing Option**

Special versions of the BSC4 can be ordered to allow addressing above 6413. The value +nn00 is shown on the build label. This jumper adds +nn00 to the phone 1 address set using SW6 and SW7. The jumper is stored on pins 4-5.

For instance by a custom version Build 7+5000 would make the jumper add 5000, the BSC4 would then be able to address from 1 to 3210 and 5001 to 8210 (Phone 1 output).

The use of this jumper precludes the use of Odd/Even addressing by PROG pins 1-2, if both are required contact Bell System Technical. The jumper is stored on pins 4-5.

## tabellet Apartment Station Switch Settings

### Mute Time Setting SW (1-4)

| 1          | 2          | 3          | 4          | Mute Time                      |
|------------|------------|------------|------------|--------------------------------|
| On         | On         | On         | On         | Disabled <sup>1</sup>          |
| Off        | On         | On         | On         | 2 minutes                      |
| On         | Off        | On         | On         | 5 minutes                      |
| Off        | Off        | On         | On         | 10 minutes                     |
| On         | On         | Off        | On         | 15 minutes                     |
| Off        | On         | Off        | On         | 20 minutes                     |
| On         | Off        | Off        | On         | 30 minutes                     |
| Off        | Off        | Off        | On         | 45 minutes                     |
| On         | On         | On         | Off        | 1 hour                         |
| Off        | On         | On         | Off        | 2 hours                        |
| On         | Off        | On         | Off        | 4 hours                        |
| Off        | Off        | On         | Off        | 5 hours                        |
| On         | On         | Off        | Off        | 6 hours                        |
| Off        | On         | Off        | Off        | 8 hours                        |
| On         | Off        | Off        | Off        | 10 hours                       |
| <b>Off</b> | <b>Off</b> | <b>Off</b> | <b>Off</b> | <b>*Indefinite<sup>2</sup></b> |

SW



OFF ↔ ON

<sup>1</sup>Default setting<sup>1</sup>Disabled means touching the ***mute*** symbol has no effect.

<sup>2</sup>Indefinite; the ***mute*** is cancelled by touching the symbol again.

### Individual Functions DIP-SW (5-8)

SW



OFF ↔ ON

| SW-5 | Master / Extension     | Which Apartment Station to set                            |
|------|------------------------|---|
| *Off | Master                 | Only or first apartment station per BSC4 output.          |
| On   | Extension / Slave      | Second and subsequent apartment stations per BSC4 output. |
| SW-6 | Auto Display on Ring   | Apartment Station display behaviour                       |
| *Off | Display during ring    | Picture is on while ringing, stays on when answered.      |
| On   | No display during ring | Picture is off while ringing, comes on when answered.     |
| SW-7 | Spare                  | Spare   |
| *Off |                        |   |
| On   |                        |   |
| SW-8 | Spare                  | Spare   |
| *Off |                        |   |
| On   |                        |   |

\*Default setting

### Video Terminator Jumper Setting

The jumper is situated next to the input connector. It is 3 pin and labelled On and Off.

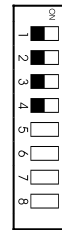
The jumper should be on when there is only one apartment station on an individual BSC4 output. Otherwise only the last apartment station should have a jumper set to On the rest being set to Off.

## BS Videophone Switch Settings

### Mute Time Settings (1-4)

| 4          | 3          | 2          | 1          | Mute Time                      |
|------------|------------|------------|------------|--------------------------------|
| On         | On         | On         | On         | Disabled <sup>1</sup>          |
| On         | On         | On         | Off        | 2 minutes                      |
| On         | On         | Off        | On         | 5 minutes                      |
| On         | On         | Off        | Off        | 10 minutes                     |
| On         | Off        | On         | On         | 15 minutes                     |
| On         | Off        | On         | Off        | 20 minutes                     |
| On         | Off        | Off        | On         | 30 minutes                     |
| On         | Off        | Off        | Off        | 45 minutes                     |
| Off        | On         | On         | On         | 1 hour                         |
| Off        | On         | On         | Off        | 2 hours                        |
| Off        | On         | Off        | On         | 4 hours                        |
| Off        | On         | Off        | Off        | 5 hours                        |
| Off        | Off        | On         | On         | 6 hours                        |
| Off        | Off        | On         | Off        | 8 hours                        |
| Off        | Off        | Off        | On         | 10 hours                       |
| <b>Off</b> | <b>Off</b> | <b>Off</b> | <b>Off</b> | <b>*Indefinite<sup>2</sup></b> |

#### Settings



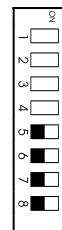
OFF ↔ ON

<sup>1</sup>Default setting<sup>1</sup>Disabled means touching the ***mute*** symbol has no effect.

<sup>2</sup>Indefinite; the ***mute*** is cancelled by touching the symbol again.

### Individual Functions Settings (5-8)

#### Settings



OFF ↔ ON

| SW-5 | Master / Extension     | Which Videophone to set                               |
|------|------------------------|---|
| *Off | Master                 | Only or first videophone per BSC4 output.             |
| On   | Extension / Slave      | Second and subsequent videophones per BSC4 output.    |
| SW-6 | Auto Display on Ring   | Videophone display behaviour                          |
| *Off | Display during ring    | Picture is on while ringing, stays on when answered.  |
| On   | No display during ring | Picture is off while ringing, comes on when answered. |
| SW-7 | Spare                  | Spare   |
| *Off |                        |   |
| On   |                        |   |
| SW-8 | Spare                  | Spare   |
| *Off |                        |   |
| On   |                        |   |

\*Default setting

### Video Terminator Jumper Setting

The jumper is situated above the input connector. It is 3 pin and labelled On and Off.

The jumper should be on when there is only one videophone on an individual BSC4 output. Otherwise only the last videophone should have a jumper set to On the rest being set to Off.



## Troubleshooting

### Common Faults

A very high percentage of calls to our technical support number, regarding new installations, are resolved to faulty wiring. The reasons for these are various: –

Broken cores, especially short links, sometimes broken inside the insulation!

Connectors clamped onto the insulation instead of copper.

Wire in the wrong side of a rising clamp connection, the clamps need to be unscrewed far enough to stop the wire going “underneath”.

Shorts or opens due to cables having been stapled or nailed through.

A common fault is wiring a connector left to right instead of right to left, or one or more twisted pairs the wrong way round.

**Tip.** The heads of screws on connectors are not a reliable means of making a connection with a meter, try pushing the probe into the wire entry point.

### Quick Fault Reference

These tables provide a quick indication of the possible fault.

| <b>Power Problems</b>   |   |
|---|---|
| Videophone resetting<br>(The three indicators lights show the power on sequence). | <ul style="list-style-type: none"> <li>• Power supply intermittent short or overload.</li> <li>• More than 1 extension enabled for auto display.</li> <li>• Lock output short-circuit; see ‘Lock Problems’</li> </ul>     |
| 28V LED does not light on controller.   | <ul style="list-style-type: none"> <li>• Temporarily remove connection to 28V+ output. If it now comes on there is a short on the videophone wiring.</li> <li>• 12V input connections are reversed or missing.</li> </ul> |
| PS4 output voltage fluctuating, meter reading unstable.                           | <ul style="list-style-type: none"> <li>• Output overload is causing current limit to operate; check allocation of controllers to power supplies, see page 5 for details.</li> <li>• See Lock Problems below.</li> </ul>   |

| <b>Panel Display Problems</b>   |  |
|---------------------------------|--|
| No display                      | <ul style="list-style-type: none"> <li>• No power at display, check for a minimum of 10V.</li> <li>• To test display, cycle the power on BFD-DIG and check for both version numbers displayed. “BDV1” then “V4.0”</li> </ul>   |
| Fault Code F1                   | <ul style="list-style-type: none"> <li>• “D” connection open circuit.</li> </ul>   |
| Fault Code F2                   | <ul style="list-style-type: none"> <li>• “D” connection: no data received.</li> <li>• “D” connection shorted to 0V</li> </ul>  |
| Display indicates “Call Failed” | <ul style="list-style-type: none"> <li>• Apartment number entered was called but did not respond. In a large system with BSSW controller, the panel at the gate displays Fail when the block with that apartment number is Busy. Otherwise see Call Problems below.</li> </ul> |

| <b>Videophone, Video or Audio Phone Call Problems</b>                         |  |
|---|--|
| Videophone does not ring or flash when called.<br><br>Display indicates Fail. | <ul style="list-style-type: none"> <li>• Videophone off hook or muted.</li> <li>• No power to videophone; check that the mute lamp illuminates when the mute symbol is touched.</li> <li>• Data wiring has a fault, Data A or Data B connection broken.</li> <li>• 0V to controller missing on separately powered videophone.</li> </ul> |
| No extension videophone rings or flashes when called.                         | <ul style="list-style-type: none"> <li>• Data wiring has a fault, Data A or Data B connection broken.</li> </ul>   |
| Green Lock light on videophone flashes once when called.                      | <ul style="list-style-type: none"> <li>• Videophone set to extension with no master present or responding.</li> </ul>  |

### **BSC4 Video Controller Tests**

When the system is idle (no calls in progress) pressing the 'Test' button activates the 'Audio On', 'Status' and one of the 'Select n' LED's for 3S. If the system is not idle (Version 2 only) pressing the 'Test' button will cause a system wide reset.

There are 4 green LED's which indicate power to the individual phones, on board fuses will operate if a short exists.

The BSC4 also has 4 'Phone' test buttons which can be used to verify the 'data' connection to the videophone. Pressing the 'Test Phone n' button should cause the videophone and extensions, if any, to ring and the associated 'Select n' Led to light.

Touching **pickup** or touching **view** will cause the 'Audio On' and 'Select n' LED's to light. There will be no audio as no door panel is active. The display on the apartment station will light up to grey or blue unless the video camera is directly wired to the BSC4 input.

Touching **pickup** again will cause all the LED's to extinguish. Touching the **lock** symbol instead will cause the 'Status' LED to light and after 3S all the LED's will go off.

If this sequence works repeatedly then the A and B data connections are probably OK. and the +28V and 0V must also be OK. The test also shows that the BSC4 software is running and diagnostics can now focus on the door controller to video controller wiring.

If it fails an videophone can be connected locally with a short cable to eliminate the cable being faulty.

| <b>Speech Problems</b>                                 |   |
|--|---|
| Loud tone at the entrance speaker. (Acoustic feedback) | <ul style="list-style-type: none"> <li>• Broken Audio 1 or Audio 2 connection.</li> <li>• Intermittent or broken Data A or Data B connection.</li> <li>• Videophone has reset; see the power faults table.</li> </ul> |
| No speech from videophone to entrance                  | <ul style="list-style-type: none"> <li>• Missing or Broken Spkr + or Spkr – connection.</li> </ul>  |
| No speech from entrance to videophone                  | <ul style="list-style-type: none"> <li>• Missing or Broken PM + or PM – connection.</li> </ul>  |

## BG bellagio Digital Video Entry System

| <b>Lock Release Problems</b>  |   |
|---|---|
| Lock release does not operate or clicks but does not open.                          | <ul style="list-style-type: none"> <li>• Connections to Lock Release are open or shorted.</li> <li>• Voltage drop due to cable too thin.</li> <li>• Lock current is too high; Power supply is resetting.</li> <li>• Lock release jammed due to over tight fitting.</li> </ul> |
| Maglock does not hold strongly.   | <ul style="list-style-type: none"> <li>• Voltage drop due to cable being too thin.</li> </ul>   |
| <b>TEST:</b><br>Press ' <b>Test</b> ' Button on Door Controller (when system idle): | <ul style="list-style-type: none"> <li>• Confirm 'LOCK' LED illuminates for 3 seconds.</li> <li>• Check Output Voltage at LOCK terminals.</li> </ul>  |
| Lock release operates all the time or in reverse                                    | <ul style="list-style-type: none"> <li>• See Panel Programming – Lock on page 23 and check that the correct lock type is selected.</li> <li>• Normally closed switch has been used for exit button.</li> </ul>  |
| Lock operates from the exit button but not the test button or videophone.           | <ul style="list-style-type: none"> <li>• Normally closed switch has been used for exit button.</li> </ul>   |

| <b>Video Problems</b>  |   |
|--|---|
| Blank picture when: -<br>Calling videophone or<br>Touching <b>view</b>     | <ul style="list-style-type: none"> <li>• Broken or missing Video + or Video – connection.</li> <li>• Cameras incorrectly configured refer to <b>CAM2</b> setting on page 23</li> <li>• Call is from an audio only panel.</li> </ul>   |
| No picture when calling videophone   | <ul style="list-style-type: none"> <li>• Check auto display switch is on. See page 31</li> </ul>  |
| No picture when touching <b>view</b>                                       | <ul style="list-style-type: none"> <li>• CCTV is not available on digital controllers</li> </ul>  |
| Repeated touching of <b>view</b> does not select cameras as expected.      | <ul style="list-style-type: none"> <li>• Check <b>CAM2</b> setting at all entrances is set for correct number of cameras at that entrance</li> </ul>  |
| Unstable picture   | <ul style="list-style-type: none"> <li>• Power supply voltage low.</li> <li>• Terminator switch not set on last videophone.</li> <li>• Too many terminator switches set on.</li> <li>• Video gain jumper set to high on a short run.</li> <li>• Very bright area in background upsetting camera.</li> </ul> |
| Unstable picture possibly with areas looking like a photographic negative. | <ul style="list-style-type: none"> <li>• Video + and – reversed, or M and S reversed.</li> </ul>  |

## Specifications

| <b>Bellagio Door Panels</b> |   |
|-----------------------------|---|
| BGP-* Surface Mount         | 140mm x 400mm x 40mm                                |
| BGP-* -F Flush Mount        | 170mm x 430mm x 40mm<br>140mm x 400mm x 35mm cutout |

| <b>BFD-DIG Door Controller</b> |   |
|--------------------------------|---|
| Size                           | 185mm x 230mm x 42mm  |
| Supply Voltage                 | 10.8V min, 13.8V typical, 15V max                                       |
| Current Consumption            | 80mA idle @13.8V, 500mA active<br>Includes display, speech not cameras. |

| <b>BSC4 Video Controller</b> |                                   |
|------------------------------|-----------------------------------|
| Size                         | 185mm x 230mm x 42mm              |
| Supply Voltage               | 10.8V min, 13.8V typical, 15V max |
| Current Consumption          | 350mA idle, 3A max @13.8V         |

| <b>BSSW Gate Controller / Block Isolator</b> |                                   |
|--|-----------------------------------|
| Size   | 185mm x 230mm x 42mm              |
| Supply Voltage                               | 10.8V min, 13.8V typical, 15V max |
| Current Consumption                          | 80mA idle, 210mA max @13.8V       |

| <b>tabellet Colour Apartment Station</b> |  |
|--|--|
| Size                                     | 144mm x 202mm x 50mm (20mm When flush)                       |
| Fixing                                   | Wall Mounted   |
| Supply Voltage                           | 11V minimum – local power supply only.<br>20V to 28V typical |
| Current Consumption                      | 25mA @28V idle, 375mA @ 11V active                           |
| Buzzer Mute Time                         | Disabled, 1minute through 10 hours, indefinite               |

| <b>BS Colour Video Phone</b> |  |
|------------------------------|--|
| Size                         | 180mm x 225mm x 60mm   |
| Fixing                       | Wall Mounted   |
| Supply Voltage               | 11V minimum – local power supply only.<br>20V to 28V typical |
| Current Consumption          | 25mA @28V idle, 375mA @ 11V active                           |
| Buzzer Mute Time             | Disabled, 1minute through 10 hours, indefinite               |

| <b>Model XL5-BS Phone</b> |                                |
|---------------------------|--------------------------------|
| Size                      | 207mm x 85mm x 60mm            |
| Supply Voltage            | 10V DC minimum, 30V DC maximum |
| Current consumption       | 20mA idle, 67mA ringing @13.8V |

## BG bellagio Digital Video Entry System

| <b>PS4 Power Supply</b>    |  |
|----------------------------|--|
| Size                       | 236mm x 105mm x 81mm                           |
| Output Voltage (regulated) | 13.5V d.c. min, 13.8V d.c. nom, 14.1V d.c. max |
| Output Current             | 3A continuous, 4A peak (5 minutes max)         |
| Mains Supply Internal Fuse | Not user replaceable                           |
| Supply Voltage             | 230V 50Hz nominal                              |
| Temperature Range          | 0 °C to 50 °C                                  |

| <b>340C Power Supply</b>   |  |
|----------------------------|--|
| Size                       | 140mm x 60mm x 53mm                      |
| Output Voltage (regulated) | 13.5V Min, 13.8V Nom, 14.1V Max          |
| Output Current             | 1A continuous, 1.5A peak (5 minutes max) |
| Mains Supply Internal Fuse | Not user replaceable                     |
| Supply Voltage             | 230V 50Hz nominal                        |
| Temperature Range          | 0 °C to 50 °C                            |

| <b>840 Power Supply – Battery Backed</b> |  |
|--|--|
| Size                                     | 350mm x 330mm x 80mm                   |
| Output Voltage (regulated)               | 13.5V Min, 13.8V Nom, 14.1V Max        |
| Output Current                           | 3A continuous, 4A peak (5 minutes max) |
| Mains Supply Internal Fuse               | T2A 20mm HBC (HRC) Ceramic             |
| Battery Fuse                             | F4A 20mm Glass                         |
| Supply Voltage                           | 230V 50Hz nominal                      |
| Temperature Range                        | 0 °C to 50 °C                          |

## Safety Information and Declarations

Connections to the 240VAC mains supply must be carried out by a qualified electrician or similar competent person, and made in accordance with current legislative requirements. A two-pole switch (as provided by a Consumer Unit or Switch-Fuse) must be included to isolate both Live and Neutral during Installation or Maintenance. The circuit must be protected by a fuse or other current-limiting device, rated according to the capacity of the cable used, up to a maximum of 10A. Use only mains cable to BS6004 or equivalent, within the following specified limits:

|                    | Min                         | Max                        |
|--------------------|-----------------------------|----------------------------|
| Conductor Diameter | 1.0mm (0.8mm <sup>2</sup> ) | 2.25mm (4mm <sup>2</sup> ) |
| Cable Diameter     | 4.0mm                       | 8.0mm                      |

### Model 840 Power Supply (with battery standby)

The Model 840 power supply must be placed in a protected indoor environment such as an electrical cupboard. It must be secured to the wall with adequate fixings so that there is no possibility of it falling. The Lead-Acid Battery for the Standby Power Supply is shipped in separate packaging. It should only be connected once the system has been fully tested. Connection is made by 2 leads with spade terminals; observe the correct polarity - red to positive, black to negative. Care must be taken to ensure that the terminals of the battery are not shorted together by metal objects, as this may constitute a Fire Hazard. Do not block any vents that may be apparent.

A good mains safety earth must be connected to the cabinet housing the power supply

Where the power supply is fitted with a replaceable internal mains fuse and or battery fuse, always replace with the same type as indicated on the power supply. The fuse must be approved to BS EN 60127 or equivalent.

| Power Supply Model | Mains Fuse (Time Delay)    | Battery Fuse (Quick Blow) |
|--------------------|----------------------------|---------------------------|
| 840                | T2A 20mm HBC (HRC) Ceramic | F4A 20mm Glass            |

### Model PS4 and 340C Power Supplies

These power supplies must be wall-mounted onto plasterboard, or a similar non-conductive material, in a protected indoor environment such as an electrical cupboard.

When fitting the power supply cable (both mains and low voltage) ensure the cable entry cut-outs in the enclosure lid are no larger than necessary for the cable diameter used and under no circumstances must they be taken beyond the outer cut-out zones.



**Bell System (Telephones) Ltd.**

Presley Way,  
Crown Hill,  
Milton Keynes  
MK8 0ET.

Tel: 01908 261106 (Sales and Technical Support)

FAX: 01908 261116

E-mail: [sales@bellsystem.co.uk](mailto:sales@bellsystem.co.uk)

[technical@bellsystem.co.uk](mailto:technical@bellsystem.co.uk)

Website: [www.bellsystem.co.uk](http://www.bellsystem.co.uk)

**Standards**

This product complies with European directive 2014/30/EU on  
Electromagnetic Compatibility and Low Voltage Directive 2014/35/EU.

Emissions: Generic BS EN 61000-6-3

Immunity: Generic BS EN 61000-6-1

Low Voltage: Generic BS EN 62368-1:2014



**bell**  
**system**  
(Telephones) Ltd